

CALCULATING TIME RECORDER

# QR-375

OPERATION MANUAL

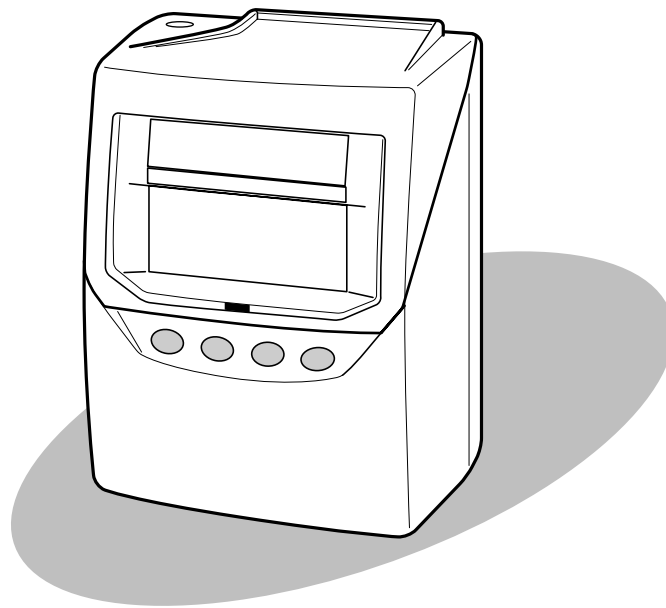

**SEIKO Precision**



# INTRODUCTION

Thank you for purchasing our Calculating Time Recorder. For safe and proper operation, please carefully read this manual before using it and save it for reference.

Bescheinigung des Herstellers/Importeurs

Dies Gerät entspricht den Bedingungen der Niederspannungs-Vorschrift 73/23/EEC und dem EMVG nach 89/336/EEC.

This unit complies with the Low Voltage Directive 73/23/EEC and the EMC Directive 89/336/EEC.

Maschinenlärminformations-Verordnung 3. GPSGV:

Der höchste Schalldruckpegel beträgt 70 dB (A) oder weniger gemäss EN ISO 7779.

Die zugehörige Steckdose muß nahe beim Gerät angebracht und leicht zugänglich sein.

1. The details of this Operation Manual are subject to change without previous notification.
2. This Operation Manual has been prepared with the utmost care to cover all aspects of the time recorder's use.  
If you feel, however, that some explanations are inadequate, unclear, or difficult to understand, please do not hesitate to contact the dealer or the shop from which you have purchased your Time Recorder.
3. Be sure to use your Time Recorder after you have fully understood the hardware and software specifications and limits.
4. No part of this publication may be reproduced, stored in a retrieval system, or transmitted, in any form or by any means, mechanical, photocopying, recording or otherwise.
  - Place the time recorder at the position close to the wall outlet so that it is easily accessible to disconnect.

Die in dieser Bedienungsanleitung enthaltenen Angaben können jederzeit ohne vorherige Ankündigung geändert werden.

Diese Bedienungsanleitung wurde mit äußerster Sorgfalt erstellt, um alle Einzelheiten hinsichtlich der Bedienung des Zeiterfassungsgerätes darzustellen. Sollten Sie dennoch Fragen haben oder Fehler in der Anleitung entdecken, nehmen Sie bitte mit uns Kontakt auf.

Wir haften nicht für direkte oder indirekte Schäden, die durch die Verwendung dieser Betriebsanleitung entstehen.

Lesen Sie diese Anleitung aufmerksam und benutzen Sie Ihr Zeiterfassungsgerät erst dann, wenn Sie die Angaben über die Hardware und Software richtig verstanden haben.

# TABLE OF CONTENTS



<b>1. PRECAUTIONS</b>	<b>1</b>
<b>2. FEATURES</b>	<b>5</b>
<b>3. BEFORE USING THE TIME RECORDER</b>	<b>6</b>
Accessories	6
Features	6
Installing the Ribbon Cassette	7
Wall Mounting	9
Environmental Conditions	9
<b>4. DAILY OPERATIONS</b>	<b>10</b>
Card number transfer	11
Card resetting	13
All cards resetting	13
<b>5. WHAT YOU CAN DO WITH THE QR-375</b>	<b>14</b>
Schedule	14
Rounding	15
Special mark printing	15
<b>6. SETTING</b>	<b>16</b>
Preparation for setting	16
Setting 12/24 hour format	17
Setting the Time	18
Setting the Date	19
Setting the Pay Period	20
Monthly Closing	20
Weekly Closing	21
Bi-Weekly Closing	22
Setting the Day Advance Time	23
Setting the Schedule	24
Common schedule	24
Max In Value	27
Extra schedule	28
Special mark printing	31
Setting the Rounding Punch	33
Setting the Daylight Saving Time	34
Deleting the daylight saving time settings	37
Setting the Print Language	38
Resetting	39
<b>7. PRINT EXAMPLE</b>	<b>40</b>
<b>8. INSTALLING THE BATTERY (OPTIONAL)</b>	<b>42</b>
<b>9. TROUBLESHOOTING</b>	<b>43</b>
<b>10. SPECIFICATIONS</b>	<b>44</b>





# 1. PRECAUTIONS







This operation manual is prepared for safe and proper use of the unit. Please follow all the instructions to avoid possible danger to yourself or others and damage to the unit.

## Signs

Various warnings and cautions are provided throughout this manual along with signs. Remember each sign and its explanation listed below for your safety and proper operation of the unit.

	<b>Warning</b>	Improper handling may cause bodily accidents including death and serious injury.
	<b>Caution</b>	Improper handling may harm the human body or material.

	Improper handling may cause electric shock DANGER.		"Must-Do" sign.
	DO NOT disassemble the unit.		Be sure to remove the line cord plug from the outlet.
	"Don't" sign.		

 <b>Warning</b>	
	Do not disassemble the unit. There is a high voltage present inside, possibly leading to an electric shock.
	Do not modify the unit. Modifications may cause a fire and/or electric shock.
	If any anomaly occurs, for example, heat or smoke is generated or an odor is emitted, unplug the unit immediately and contact your dealer for servicing. There is a danger that further use may cause a fire or electric shock.
	Do not use any voltage of the power source other than designated. Do not share a single outlet with another plug. These may lead to fire or shock hazards.
	Do not damage, break, or modify the power cord. Do not put a heavy object on, pull, or forcefully bend the cord, either. These may damage the cord, possibly resulting in a fire or electric shock.

 If foreign matter should get in the unit (including a piece of metal, water, or liquid), disconnect the plug from the outlet immediately and contact your dealer for servicing. There is a danger that further use may cause a fire or electric shock.

 Do not plug or unplug the unit with a wet hand. You may get an electric shock.

 **Caution**

 Do not place the unit on an uneven or tilted surface. This may result in injuries due to the unit dropping or falling off.

 Do not put a water-filled container or a metal object on top of the unit. If water is spilled or the metallic object slips inside, a fire or shock hazard may occur.

 Do not install the unit in a humid or dusty environment. It may cause a fire or electric shock.

 Do not place the unit near kitchen counter or humidifier. Oil, smoke, or steam generating from them may cause fire or shock hazards.

 Do not yank the power cord to disconnect from the outlet. Hold the plug with your hand to do so, or the cord may be damaged, possibly leading to a fire or electric shock.

 Remove the line cord plug from the outlet before transferring the unit, or it may damage the cord, possibly leading to a fire or electric shock.

 Be careful not to contact the print head, as you may get hurt or burned.

 Make sure to insert the power plug as far as it will go. Improper insertion of the plug may develop fire or shock hazards.

 Do not insert or drop any other time card than specified into the slot. Such misuse may cause a fire or electric shock.

 If the unit should be dropped or the case be broken, unplug the unit and contact your dealer for servicing. Further use may lead to a fire or shock hazard.



**Daily Care**  
For cleaning, turn the power off and wipe the case clean of dust and dirt with a dry cloth, etc.





# 1. Vorsichtsmassnahmen







Dieses Bedienerhandbuch stellt die sichere und ordnungsgemäße Verwendung des Geräts sicher. Befolgen der Anweisungen schützt den Bediener und andere vor Verletzungen und verhindert die Beschädigung des Geräts.



## Warnschilder

Nachfolgend werden Schilder mit Warn- und Vorsichtshinweisen dargestellt. Um das Gerät sicher und ordnungsgemäß handhaben zu können, hat sich der Bediener jedes Schild und die nachstehende Erklärung zu beachten.

	<b>Achtung</b>	Unangebrachte Handhabung kann zu Unfällen mit ernststen und tödlichen Körperverletzungen führen.
	<b>Vorsicht</b>	Unangebrachte Handhabung kann zu Körperverletzungen oder Sachschäden führen.

	Unangebrachte Handhabung kann zu GEFAHREN wie elektrischen Schlag führen.		Das Schild weist auf unbedingt erforderliche Handlungen hin.
	Das Gerät NICHT auseinandernehmen.		Den Stecker des Anschlußkabels aus der Netzsteckdose ziehen.
	Das Schild weist auf zu unterlassende Handlungen hin.		

 <b>Achtung</b>	
	Das Gerät nicht auseinandernehmen. Die hohe Spannung im Gehäuse könnte zu einem elektrischen Schlag führen.
	Das Gerät nicht umbauen. Änderungen könnten ein Feuer verursachen und/oder zu einem elektrischen Schlag führen.
	Tritt ein abnormaler Zustand ein, das Gerät wird z.B. heiß, raucht oder ein Geruch macht sich bemerkbar, sofort den Stecker aus der Netzsteckdose ziehen und den Kundendienst des Händlers benachrichtigen. Die weitere Verwendung könnte ein Feuer verursachen oder zu einem elektrischen Schlag führen.
	Das Gerät nur an eine Stromquelle mit der vorgeschriebenen Spannung anschließen. Anschluss von zwei Geräten an eine Netzsteckdose vermeiden, da dies ein Feuer verursachen oder zu einem elektrischen Schlag führen könnte.
	Das Anschlusskabel vor Beschädigung oder Bruch schützen und auf keine Weise ändern. Ferner keine schweren Gegenstände auf das Kabel stellen und jegliches ziehen oder knicken des Kabels unterlassen. Das Kabel wird dadurch beschädigt und könnte ein Feuer verursachen oder zu einem elektrischen Schlag führen.

	Geraten Fremdkörper (einschließlich Metallstücke, Wasser oder sonstige Flüssigkeiten) in das Gerät, sofort den Stecker aus der Netzsteckdose ziehen und den Kundendienst des Händlers benachrichtigen. Die weitere Verwendung könnte ein Feuer verursachen oder zu einem elektrischen Schlag führen.
	Den Stecker des Geräts nicht mit nassen Händen in die Netzsteckdose einstecken bzw. herausziehen, da dies zu einem elektrischen Schlag führen könnte.

 <b>Vorsicht</b>	
	Das Gerät nicht auf eine unebene oder schräge Oberfläche zu stellen. Das Gerät könnte nach unten rutschen bzw. fallen und zu Verletzungen führen.
	Die Oberfläche des Geräts nicht zum Abstellen von Wasserbehältern oder Metallgegenständen verwenden. Wenn verschüttetes Wasser eindringt oder ein Metallgegenstand in das Gerät fällt, kann dies ein Feuer verursachen oder zu einem elektrischen Schlag führen.
	Das Gerät nicht in einer feuchten oder staubigen Umgebung installieren, da dies ein Feuer verursachen oder zu einem elektrischen Schlag führen könnte.
	Das Gerät nicht in der Nähe einer Küchenanrichte oder eines Befeuchters installieren. Das dort vorhandene bzw. erzeugte Öl, Rauch oder Dampf kann ein Feuer verursachen oder zu einem elektrischen Schlag führen.
	Das Anschlusskabel nicht mit Gewalt aus der Steckdose ziehen, sondern mit der Hand entfernen. Beschädigung des Kabels könnte ein Feuer verursachen oder zu einem elektrischen Schlag führen.
	Bei Umstellen des Geräts den Stecker des Anschlusskabels aus der Netzsteckdose ziehen. Beschädigung des Kabels könnte ein Feuer verursachen oder zu einem elektrischen Schlag führen.
	Berühren des Druckkopfes vermeiden, da dies zu Verletzungen oder Verbrennungen führen könnte.
	Den Netzstecker ganz einstecken. Unangebrachtes Einstecken des Netzsteckers kann ein Feuer verursachen oder zu einem elektrischen Schlag führen.
	Nur die vorgeschriebenen Stempelkarten verwenden. Die Verwendung unangebrachter Karten kann ein Feuer verursachen oder zu einem elektrischen Schlag führen.
	Fällt das Gerät oder wird das Gehäuse beschädigt, den Netzstecker herausziehen und den Kundendienst des Händlers benachrichtigen. Die weitere Verwendung könnte ein Feuer verursachen oder zu einem elektrischen Schlag führen.

<b>Tägliche Pflege</b>	
Das Gerät ist bei der Reinigung abzuschalten und mit einem trockenen Tuch von Staub und Schmutz zu befreien.	



## 2. FEATURES

- The QR-375 has the ability to calculate the elapsed time between IN/OUT punches and also prints a running total of accumulated time.
- You can print IN/OUT as many times as you want per day.
- Automatic switching between IN/OUT print columns.
- It is possible to select one of three pay periods.  
— Monthly/ Weekly/ Bi-weekly
- You can program two types of schedules.  
— Common schedule/ Extra schedule
- The number of cards that can be automatically registered is a maximum of 50 cards.
- The unit resumes when the power returns after a power outage, without any need for re-setting the date or time.
- You can set the automatic daylight saving time program.
- The languages English · Spanish · German · French · Italian · Portuguese can be selected to print the days of the week when you are totalizing weekly or bi-weekly.
- You can set the special mark printing that makes it possible to easily see an employee's late in or early out.
- It is possible to use for wall mounting or table mounting.

# 3. BEFORE USING THE TIME RECORDER

## Accessories

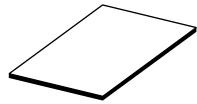

Operation Manual

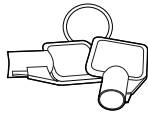

Keys

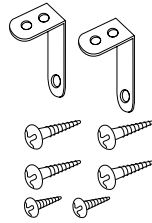

Wall Mount Screws

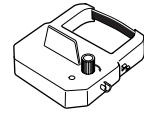

Ribbon Cassette

## Features

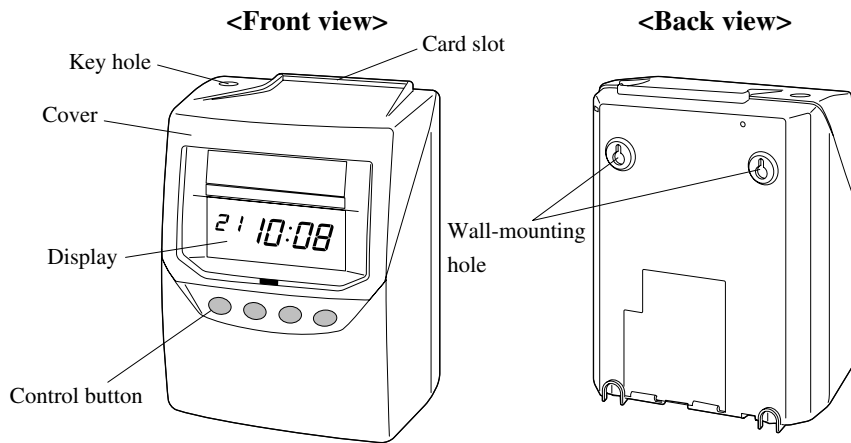

### < Display >

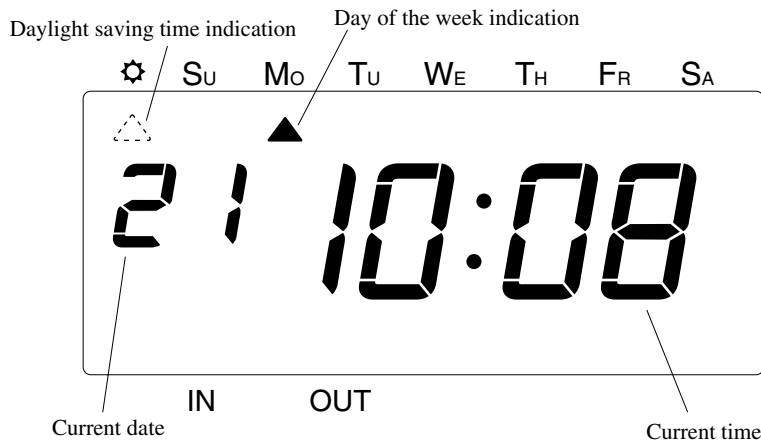

## Installing the Ribbon Cassette

Make sure the power is on before installing.

- 1 Hold the left and right sides of the cover and lift up.

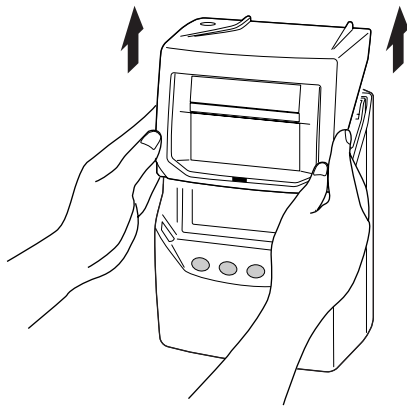

- 2 Turn the knob of the new ribbon cassette in the same direction as the arrow to tighten the ribbon.

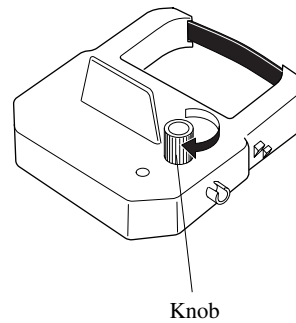

- 3 Place the ribbon cassette inside the time recorder as shown in the figure. Keep on pushing in the ribbon cassette until the clasps at both sides catch and you hear a "pop" sound. If it is difficult to insert the ribbon cassette, try it while turning the knob.

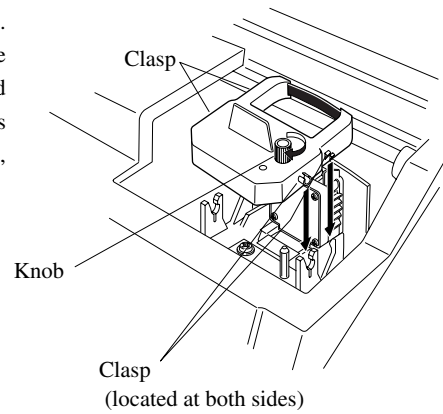

## 4 Precautions to take when replacing the ribbon

Take the following precautions when inserting a new ribbon cassette.

**Install the ribbon cassette so that the ribbon is between the print head and the ribbon mask (see the figure on the left). Printing will not come out properly if the ribbon is placed behind the ribbon mask (see the figure on the right).**

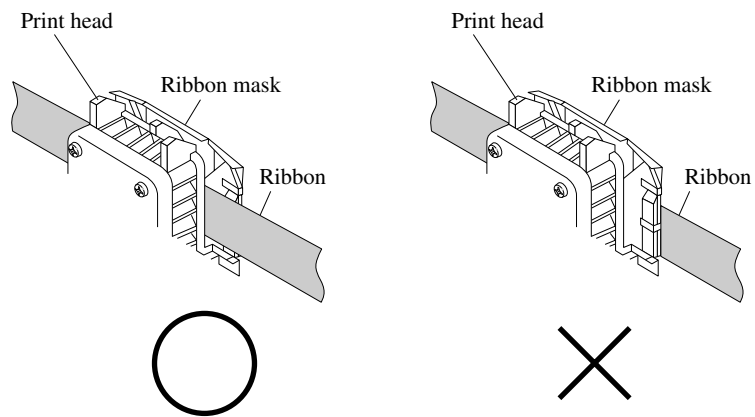

- 5** Turn the knob of the ribbon cassette in the direction of the arrow to tighten the ribbon.

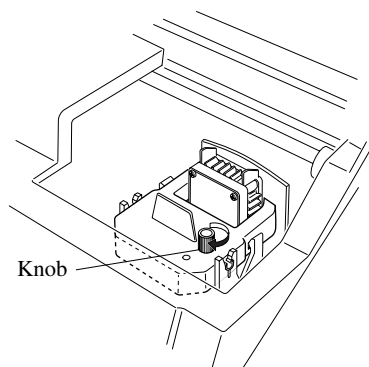

- 6** Replace the cover by fitting the plugs at both sides of the cover into the holes located on the unit of the body, and while pulling the cover toward yourself, push down.

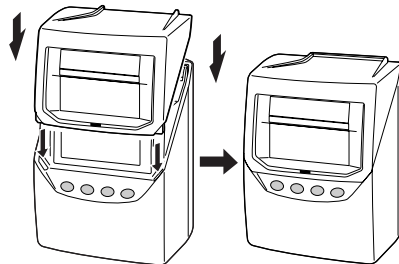

---

## Wall Mounting

The unit can be mounted on a wall using the wall mount screws supplied. To mount the unit on a wall, take the following steps:

- 1 Install wall mount screws (supplied) into a wall 3.94 inches (10 cm) apart. Be sure to keep about 0.12 inch (3 mm) of the screw head out of the wall.



The supplied screws are intended for use on a thick wooden wall or wooden column. Do not use them on any other materials. There is a danger that the unit may come off if used on other materials.

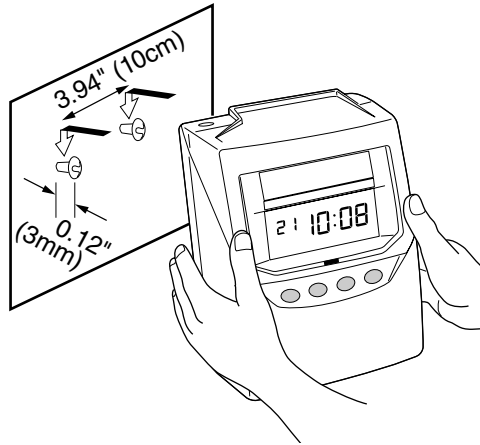

- 2 Mount the wall mount fittings as shown on the right.

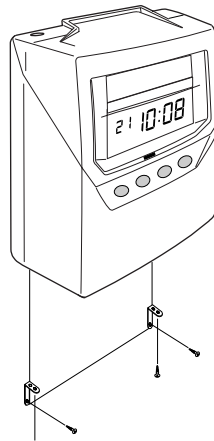

---

## Environmental Conditions

Avoid placing the unit in environments that are:

- humid or dusty
- exposed to direct sunshine
- subject to frequent or continuous vibrations
- outside the temperature range between  $-5^{\circ}$  and  $45^{\circ}$  C
- affected by chemicals or ozone

## 4. DAILY OPERATIONS

Once the AC line cord is plugged into the outlet, the unit can be used immediately. Basic operations, including the time and closing dates, are preset.

See "3. BEFORE USING THE TIME RECORDER"

It is easy to operate the unit. Just insert a time card. The card is then automatically pulled in, printed and then ejected.



Do not let any metallic object get into the slot, including paper clips. Do not forcefully push in a card, either. These may cause the unit to malfunction.

The number of cards that can be automatically registered is a maximum of 50 cards.

- When a new card is inserted, the card will automatically be registered, and will print the "IN" print on the first line. The month will be printed on the first line also or on the line when the month and printing line change.
- You can print "IN" and "OUT" as many times as you want per day. Concerning the printing line, it will slide one line down each time you insert the card for "IN" print.
- The recorder will judge the last imprint and automatically switch the "IN" and "OUT". And also you can manually switch the column position of imprint by push the "IN" button or "OUT" button.

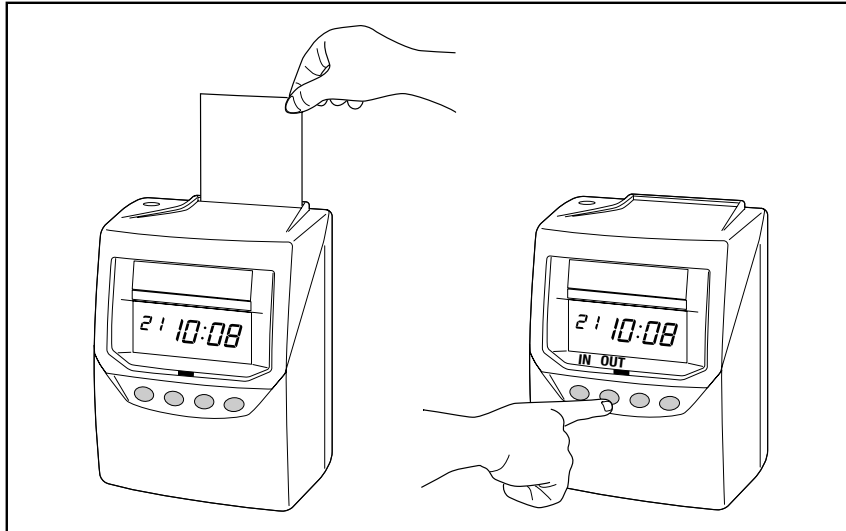

- Even if the "IN" is printed, when the present time passes the "Day Advance Time", it will judge that the "OUT" print was forgotten and will print the "IN" print on the next line.

## Card number transfer

When the card that you are using becomes full before reaching the "Pay Period" day, it will show "END" on the display and the buzzer will sound. When the "END" appears, you can use the "Card number transfer" mode to transfer the card and have a new card take over from the old one.

In this function, it will be useful.....

- when the card has become full before reaching the "Pay Period".
- when the card that is being used is lost, or unable to function because of stain.
- if you want to change the card to a new one.

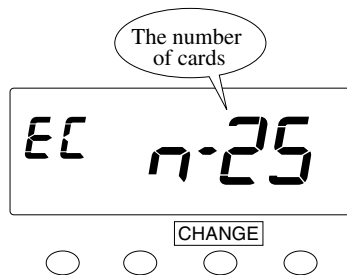
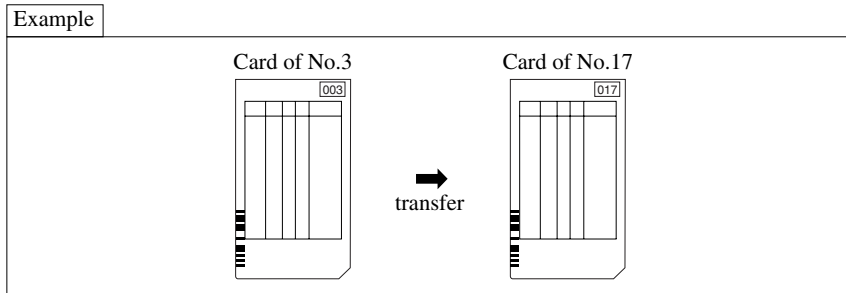

- 1 Push the **CHANGE** button for 3 seconds.

When you have a card that you are using, the number of cards that you are using will be shown on the display. If there are no cards used at the present state, it will show "n-00" and will end the mode.

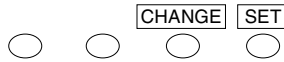
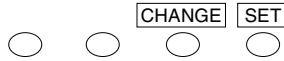
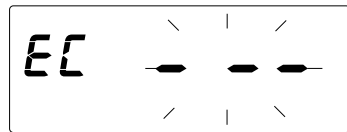
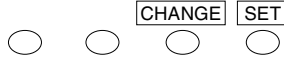

- 2** After the numbers of cards are shown, in the example, push the **CHANGE** button to show the card number "003" and then push the **SET** button.  
(Or insert the card "003".)

- 3** Push the **CHANGE** button to pick a new card number "017" and then push the **SET** button.  
(Or insert the card "017".)  
when the card number is changed, this mode will finish.



## Card resetting

When you want to reset the card manually before reaching the "Pay Period" day, you can go to the "Card resetting" mode.

### Example

The number of the card you want to reset is "003".

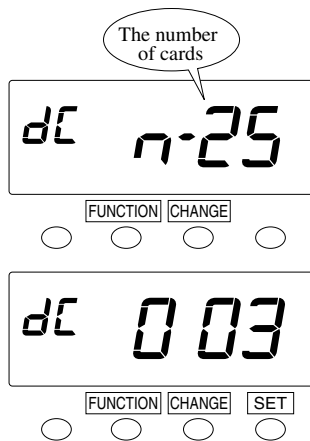

**1** Push the **FUNCTION** and **CHANGE** button for 3 seconds. The number of cards that you are using will be shown on the display.

**2** In the example, push the **CHANGE** button to show the card number "003" and then push the **SET** button.

**3** Push the **SET** button one more time.

## All cards resetting

You want to reset all cards manually.....

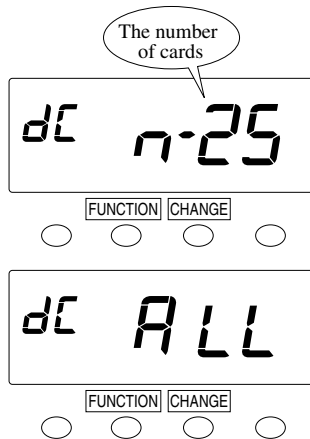

**1** Push the **FUNCTION** and **CHANGE** button for 3 seconds. The number of cards that you are using will be shown on the display.

**2** Push the **CHANGE** button to show "ALL" and then push the **SET** button.

**3** Push the **SET** button one more time.

# 5. WHAT YOU CAN DO WITH THE QR-375

## Schedule

You can select one of two types of schedules. You have the choice from a "Common schedule", which literally will be common with all days of the week, and from an "Extra schedule" that prioritizes the special day of the week.

Each schedule is made from an "Calculation effective time zone" and maximum settings of 2 "Break times", and you can regulate the day's working rules. The day's partition that is the schedule's standard is the "Day advance time", and this time is optional.

Example:

### Common schedule

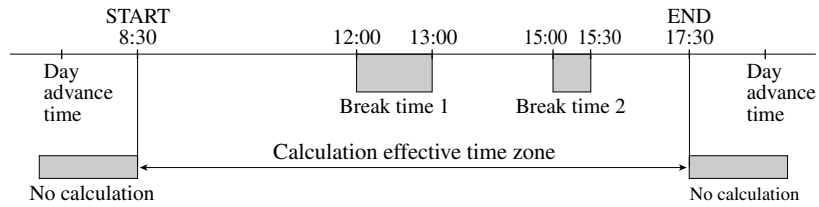

### Extra schedule

Friday

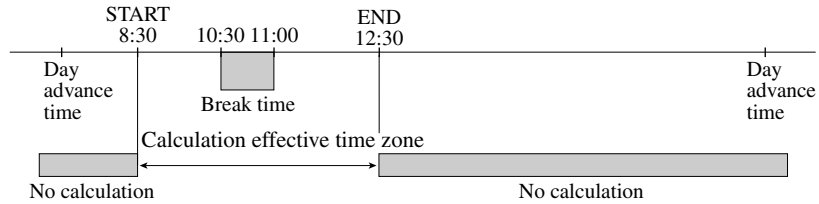

If the schedule is not set, you can regulate the working hours of the day by setting the "Max In Value".

In this case, instead of managing the time zone, you can simply accumulate hours by just the "IN" and "OUT" times. When "Max In Value" is set, you can exceed the "Day advance time".

Example:

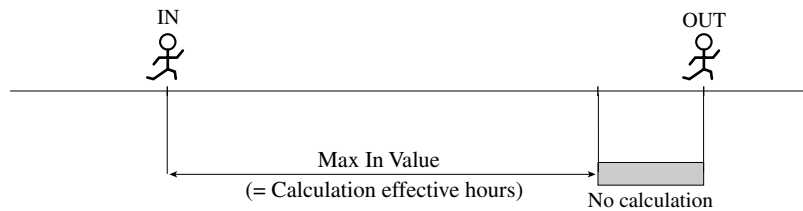

## Rounding

For Rounding, there are 2 settings: "Types of Rounding" and "Rounding Unit". For "Types of Rounding", there are "Hourly Rounding" and "Punch Time Rounding", and you can choose one.

For "Hourly Rounding", you calculate the hours from time "IN" and time "OUT", and round that result with the "Rounding Unit" that you have selected. The fractions that occur after rounding will be omitted.

For "Punch Time Rounding", the recorder rounds both the time "IN" and "OUT" and then it calculates the hours from the time "IN" and "OUT". When rounding the time "IN", it will raise the fractions that occur. And for the rounding of time "OUT", it will omit the fractions.

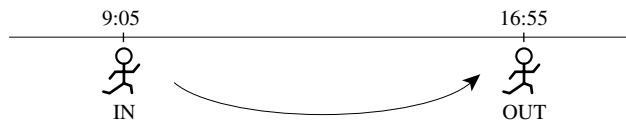

Example: Rounding Unit 15 min.

Types of Rounding	IN	OUT	Total
Hours	9:05	16:55	$16:55 - 9:05 = 7:50 \xrightarrow{\text{round}} 7:45$
Punch time	$9:05 \xrightarrow{\text{round}} 9:15$	$16:55 \xrightarrow{\text{round}} 16:45$	$16:45 - 9:15 = 7:30$

## Special mark printing

You can set the special mark printing "!" which means the punch between "Core start time" and "Core end time" except "Break time".

Special mark printing makes it possible to easily see an employee's late in or early out.

Example

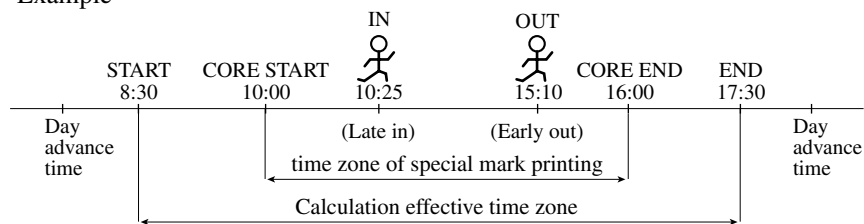

Print example

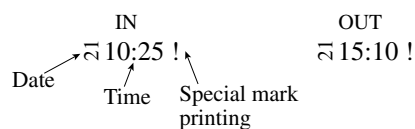

# 6. SETTING

## Preparation for setting

To prepare for setting:

**!** Make sure the power is on before making setting.

- 1** Unlock the cover.

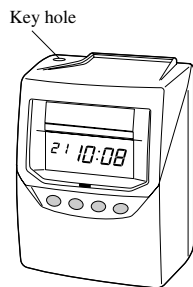

- 2** Hold the sides of the cover with both hands, and lift it.

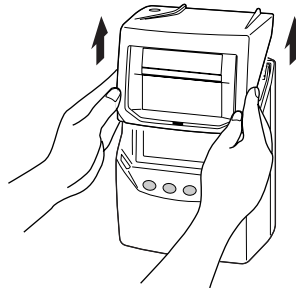

- 3** Make settings using the control button while watching the display. Please refer to the following page for the details of each setting.

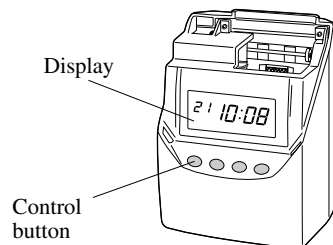

- 4** After the setting has been completed, fit the plugs at the lower sides of the cover into the holes of the unit.

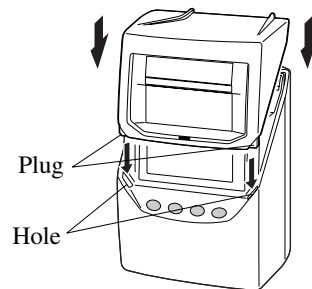

- 5** Pull back the cover while returning it from your side to the opposite side to install it.

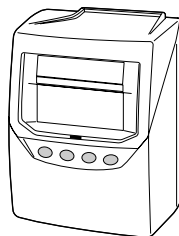

## Setting the 12/24 hour format

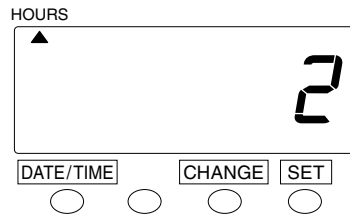
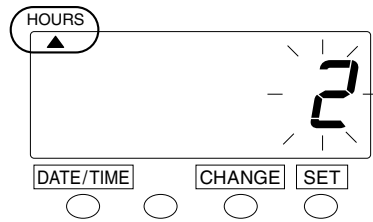

	Type of hour
1	12 hour
2	24 hour

- 1 Push the **DATE/TIME** button for 3 seconds and position the "▲" under the "HOURS" mark.
- 2 Push the **CHANGE** button to select either "12 hour" or "24 hour". For example, set 2 if 24 hour is desired.
- 3 Push the **SET** button to finish the setting. At that moment, the display will change from flashing to steady, and the setting is now completed.
- 4 Push the **SET** button once again.

## Setting the Time

**Example** To change the time from 10:08 to 10:09

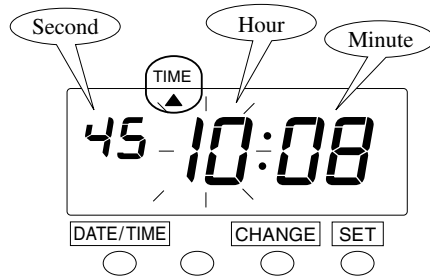

**1** Push the **DATE/TIME** button for 3 seconds.

**2** Push the **DATE/TIME** button and position the "▲" under the "TIME" mark.

The flashing number can be changed.

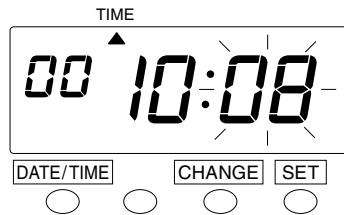

**3** In the example, push the **SET** button because the hour is not to be changed; now the hour of 10 o'clock has been set.

At that moment, the flashing of the display changes from "Hour" to "Minute".

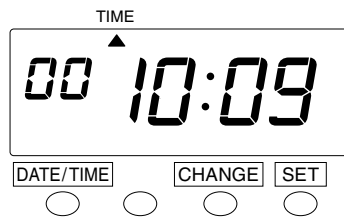

**4** Changing the "Minute" (for example, from 8 minutes to 9 minutes).

Push the **CHANGE** button to set "Minute" at "09" and then push the **SET** button. Now the minutes of 9 have been set.

**5** Push the **SET** button once again.

## Setting the Date

**Example** Change the date from October 20, 2002 to October 21, 2002.

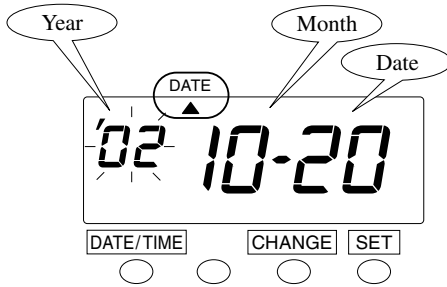

**1** Push the **DATE/TIME** button for 3 seconds.

**2** Push the **DATE/TIME** button and position the "▲" under the "DATE" mark.

A flashing number means that it can be changed.

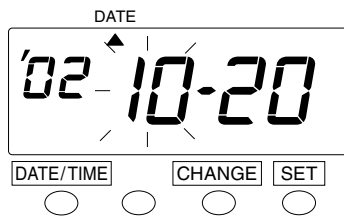

**3** In the example, push the **SET** button because the year 2002 is not to be changed. Now the year of 2002 has been set.

At that moment, the flashing of the display will change from "Year" to "Month".

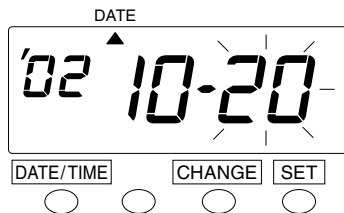

**4** In the example, push the **SET** button because the month of October is not to be changed. Now October has been set.

At that moment, the flashing of the display will change from "Month" to "Date".

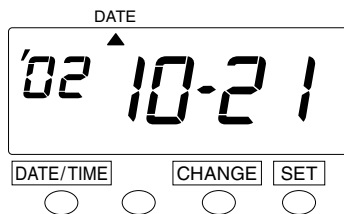

**5** Change "Date" (for example, from 20 to 21)

Push the **CHANGE** button to set "Date" at "21" and then push the **SET** button, and now the date of 21 has been set.

At that moment, "Date" on the display will change from flashing to steady, and the date change setting is now completed.

**6** Push the **SET** button once again.

## Setting the Pay Period

When you have cards that you are using . . . . .

If you try to change the settings, an error "E-49" will appear and you can not change settings. You can change settings when you reset all one. Please refer to "Resetting" or "All cards resetting".

## Monthly Closing

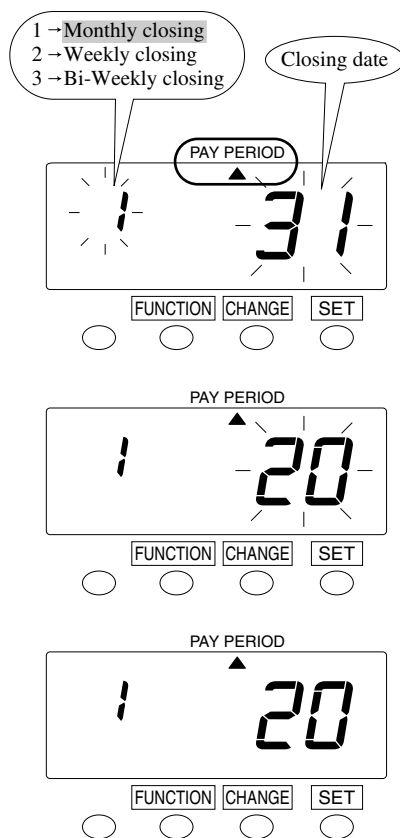

**1** Push the **FUNCTION** button for 3 seconds and position the "▲" under the "PAY PERIOD" mark.

**2** If the case is monthly closing, push the **SET** button. At that moment, the flashing of the display will change to the closing date.

**3** Push the **CHANGE** button to set the desired closing date.  
For example, if the closing date is the 20th, set the closing date at 20.

**4** Push the **SET** button to finish the setting. At that moment, the display will change from flashing to steady, and the setting is now completed.

The date and time are recorded on the card when you set the monthly closing.

**5** Push the **SET** button once again.



## Weekly Closing

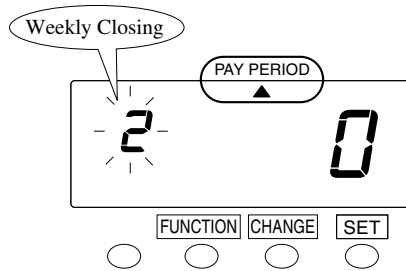

### Example

Today	July 20	Closing day
..... July 19	July 20	July 21.....
Friday	Saturday	Sunday
0	1	2

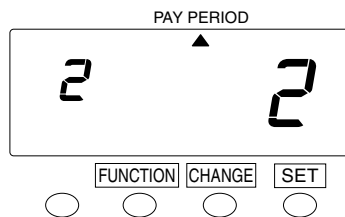
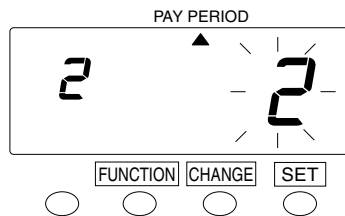

**1** Push the **FUNCTION** button for 3 seconds and position the "▲" under the "PAY PERIOD" mark.

**2** In the case of weekly closing, push the **CHANGE** button to set the left-side number at "2" and then push the **SET** button.

At that moment, the flashing of the display will change to the right-side number.

**3** Next, set the desired closing date, which comes within a week from today.

Example: Assume that today is Friday, July 19, 2002 and the closing date is Sunday. As illustrated in the figure on the left, closing day (Sunday) is two days after.

Push the **CHANGE** button to set the right-side number of the display at "2".

**4** Push the **SET** button to finish the setting. At that moment, the display will change from flashing to steady, and the setting is now completed.

The day of the week and time are recorded on the card when you set the weekly closing.

**5** Push the **SET** button once again.

## Bi-Weekly Closing

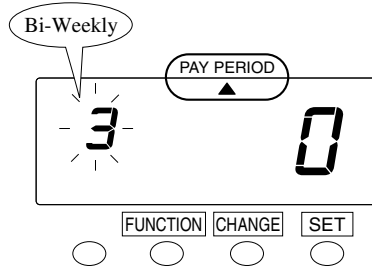

- 1 Push the **FUNCTION** button for 3 seconds and position the "▲" under the "PAY PERIOD" mark.
- 2 In the case of bi-weekly closing, push the **CHANGE** button to set the left-side number of the display at "3" and then push the **SET** button. At the moment, the flashing of the display will change to the right-side number.

### Example

Today	Closing day	
July 12	July 13..... July 20	July 21.....
Friday	Saturday Saturday	Sunday

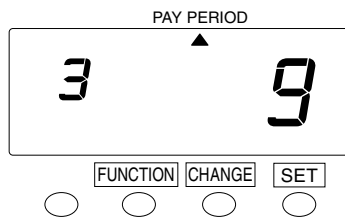
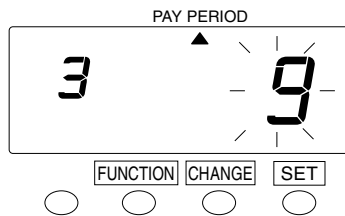
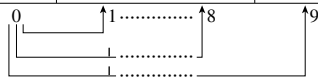

- 3 Next, set the desired closing date, which comes within two weeks from today.

Example: Assume that today is Friday, July 12, 2002 and the closing date is on Sunday the week after next. As illustrated in the figure on the left, closing day is nine days after.

Push the **CHANGE** button to set the right-side number of the display at "9".

- 4 Push the **SET** button to finish the setting. At that moment, the display will change from flashing to steady, and the setting now completed.

The day of the week and time are recorded on the card when you set the bi-weekly closing.

- 5 Push the **SET** button once again.

## Setting the Day Advance Time

The day advance time refers to the time when printing shifts to the next line on a time card for the next day. This function enables the punch out time record to print on the same line of the previous working day even if leaving time is after midnight.

### When you have cards that you are using . . . . .

If you try to change the settings, an error "E-49" will appear and you can not change settings. You can change settings when you reset all one. Please refer to "Resetting" or "All cards resetting".

**Example** Change the line shift time from 5:00 a.m. to 7:00 a.m.

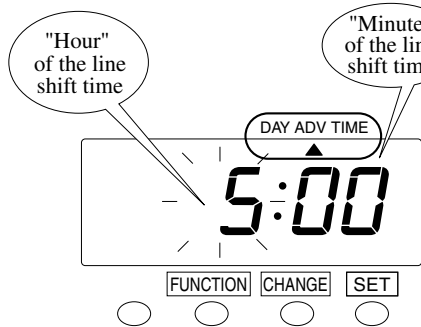

**1** Push the **FUNCTION** button for 3 seconds.

**2** Push the **FUNCTION** button and position the "▲" under the "DAY ADV. TIME" mark.

The flashing number can be changed.

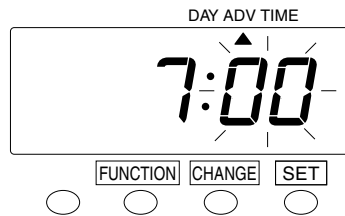

**3** Change "Hour" of the line shift time (for example, from 5:00 to 7:00). Push the **CHANGE** button to set "Hour" at "7", and then push the **SET** button.

At that moment, the flashing of the display will change from "Hour" to "Minute".

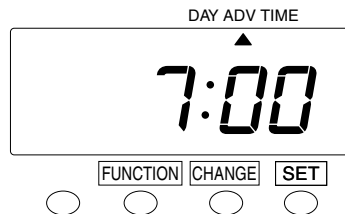

**4** Push the **SET** button once more because "Minute" is not to be changed. Now "00" minute has been set.

At that moment, "Minute" on the display will change from flashing to steady, and the setting of the day advance time is now completed.

**5** Push the **SET** button once again.

## Setting the Schedule

See "5 . WHAT YOU CAN DO WITH THE QR-375" before setting the schedule.

### Common schedule

Example 1

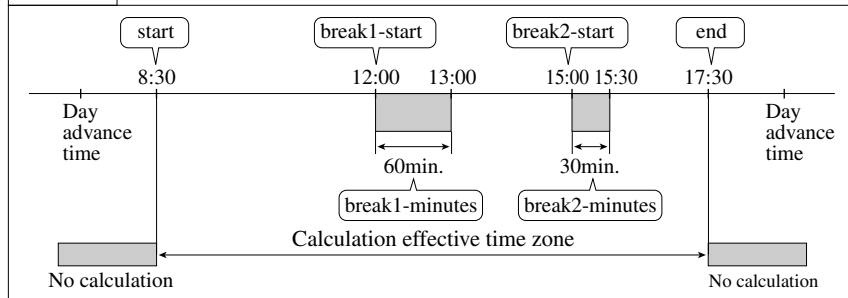

- 1 Push the **FUNCTION** button for 3 seconds.
- 2 Push the **FUNCTION** button and position the "▲" under the "COMMON SCHEDULE" mark.

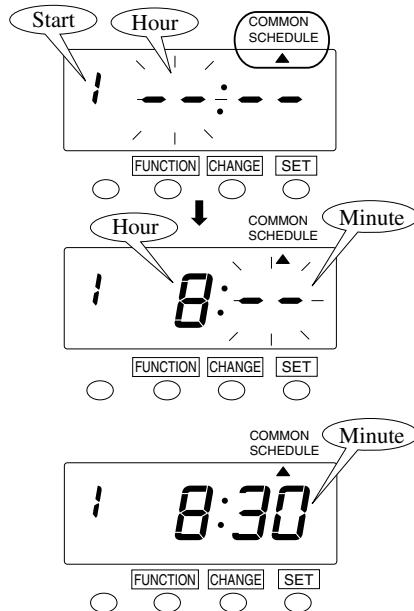

#### Set the "start" time.

- 3 Push the **SET** button. At that moment, the flashing changes to "Hour". In the case of the example, push the **CHANGE** button to set at "8" and push the **SET** button. At that moment, the flashing changes from "Hour" to "Minute".
- 4 In this case, push the **CHANGE** button to set at "30". And then push the **SET** button.

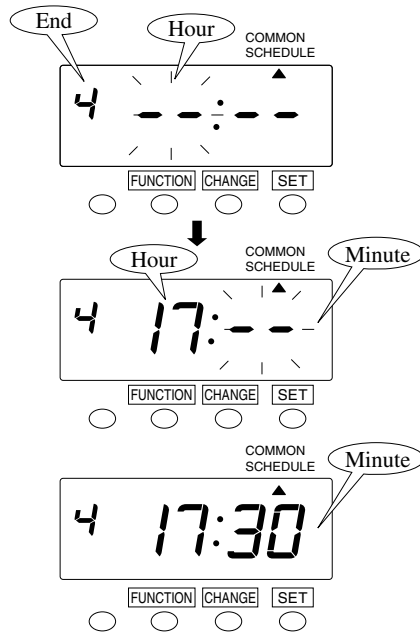

### Set the "end" time.

- 5** Next, push the **CHANGE** button 4 times to set the left-side number at "4" and then push the **SET** button. At that moment, the flashing changes to "Hour". In the case of the example, push the **CHANGE** button to set at "17" and then push the **SET** button. At that moment, the flashing changes from "Hour" to "Minute".

- 6** In this case, push the **CHANGE** button to set at "30" and then push the **SET** button.

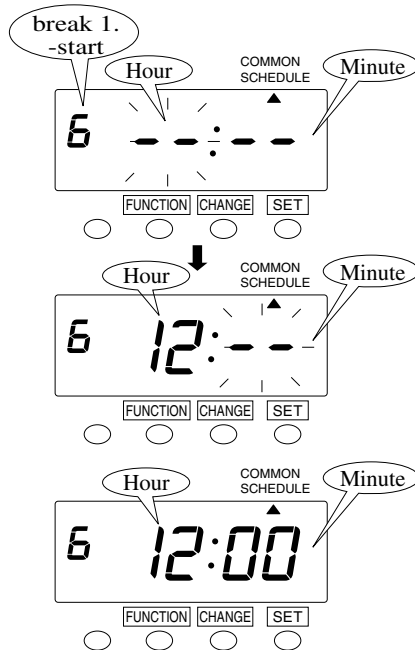

### Set the "break 1-start" time.

- 7** Push the **CHANGE** button 3 times to set the left-side number at "6" and push the **SET** button. At that moment, the flashing changes to "Hour". In the case of the example, push the **CHANGE** button to set at "12" and then push the **SET** button. At that moment, the flashing changes from "Hour" to "Minute".

- 8** In this case, push the **CHANGE** button to set at "00" and then push the **SET** button.

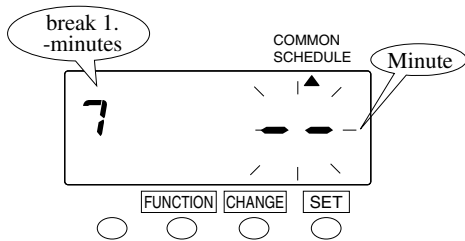

### Set the "break 1-minutes".

**9** Next, push the **CHANGE** button twice to set the left-side number at "7" and then push the **SET** button. At that moment, the flashing changes to "Minute".

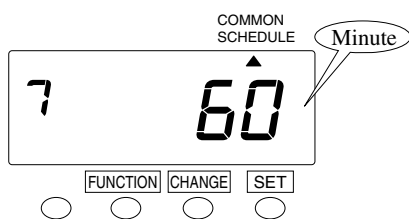

**10** In this case, push the **CHANGE** button to set at "60" and then push the **SET** button.

Range of values: 1-90 min.

### Set the "break 2-start" time.

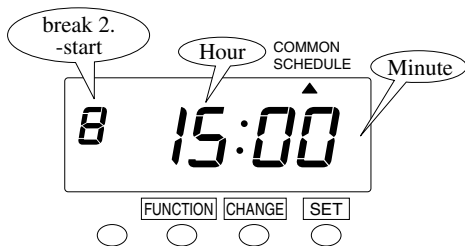

**11** Make setting for the "break 2-start" time in the same manner as for the "break 1-start" time, as illustrated in the figure on the left.

### Set the "break 2-minutes".

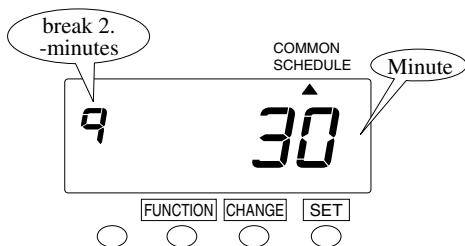

**12** Make setting for the "break 2-minutes" in the same manner as for the "break 1-minutes", as illustrated in the figure on the left.

**13** Push the **SET** button once again.



# Max In Value

If the schedule is not set, you can regulate the working hours of the day by setting the "Max In Value".

Example 2

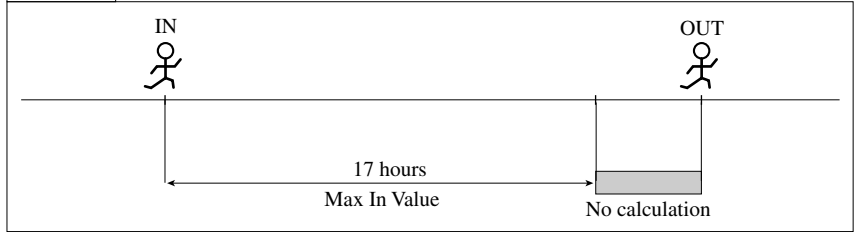

- 1 Push the **FUNCTION** button for 3 seconds.
- 2 Push the **FUNCTION** button and position the "▲" under the "COMMON SCHEDULE" mark.

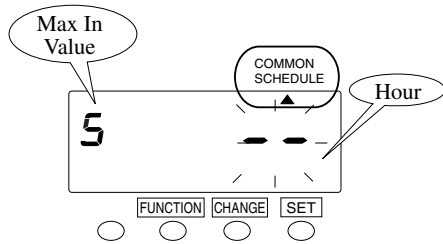

- 3 Push the **CHANGE** button 4 times to set the left-side number at "5" and then push the **SET** button. At that moment, the flashing changes to "Hour".

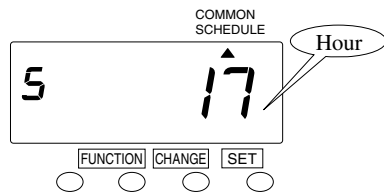

- 4 In this case, push the **CHANGE** button to set at "17" and then push the **SET** button.

Range of values: 1-24 hr.

- 5 Push the **SET** button once again.

## Extra schedule

Priority is given to "Extra schedule" over "Common schedule".

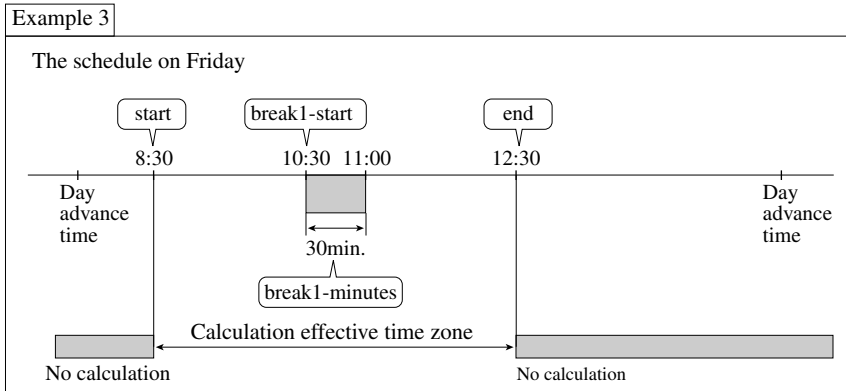

- 1 Push the **FUNCTION** button for 3 seconds.
- 2 Push the **FUNCTION** button and position the "▲" under the "EXTRA SCHEDULE" mark.

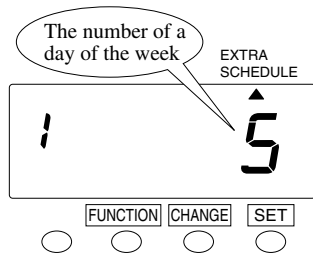
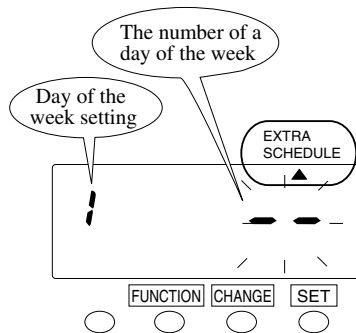

### Set the "day of the week".

1	Monday	5	Friday
2	Tuesday	6	Saturday
3	Wednesday	7	Sunday
4	Thursday		

- 3 Push the **SET** button. At that moment, the flashing changes to "The number of a day of the week".
- 4 In this case, push the **CHANGE** button to set at "5" and then push the **SET** button.



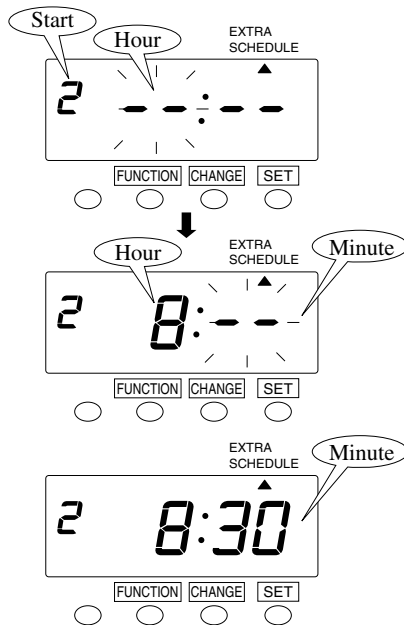

### Set the "start" time.

- 5** Push the **CHANGE** button twice to set the left-side number at "2" and then push the **SET** button. At that moment, the flashing changes to "Hour". In the case of the example, push the **CHANGE** button to set at "8" and then push the **SET** button. At that moment, the flashing changes from "Hour" to "Minute".

- 6** In this case, push the **CHANGE** button to set at "30" and then push the **SET** button.

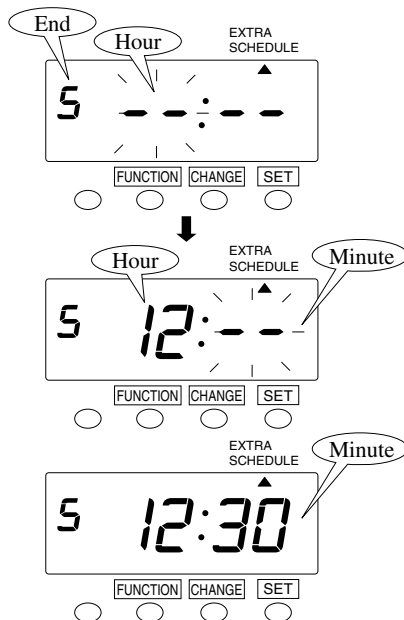

### Set the "end" time.

- 7** Next, push the **CHANGE** button 4 times to set the left-side number at "5" and then push the **SET** button. At that moment, the flashing changes to "Hour". In the case of the example, push the **CHANGE** button to set at "12" and then push the **SET** button. At that moment, the flashing changes from "Hour" to "Minute".

- 8** In this case, push the **CHANGE** button to set at "30" and then push the **SET** button.

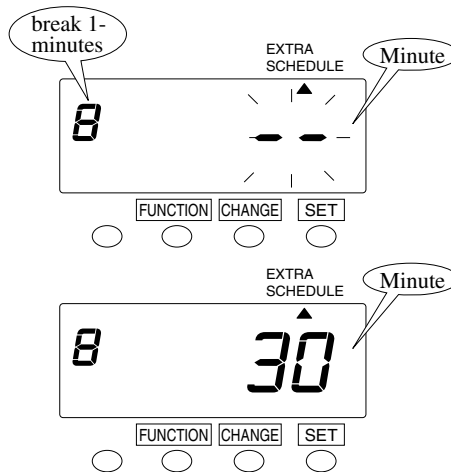
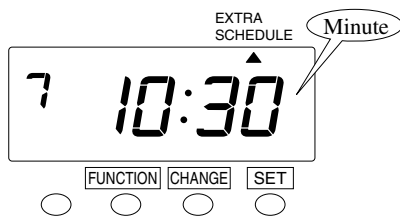
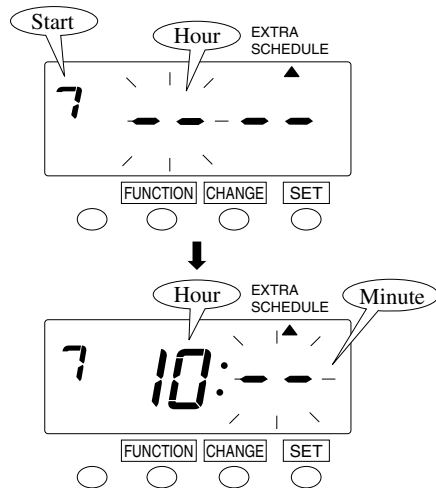

### Set the "break 1-start" time.

- Push the **CHANGE** button 3 times to set the left-side number at "7" and push the **SET** button. At that moment, the flashing changes to "Hour". In the case of the example, push the **CHANGE** button to set at "10" and then push the **SET** button. At that moment, the flashing changes from "Hour" to "Minute".

- In this case, push the **CHANGE** button to set at "30" and then push the **SET** button.

### Set the "break 1-minutes".

- Next, push the **CHANGE** button twice to set the left-side number at "8" and then push the **SET** button. At that moment, the flashing changes to "minute".

- In this case, push the **CHANGE** button to set at "30" and then push the **SET** button.

Range of values: 1-90 min.

- Push the **SET** button once again.

## Special mark printing

Special mark printing makes it possible to easily see an employee's late in or early out.

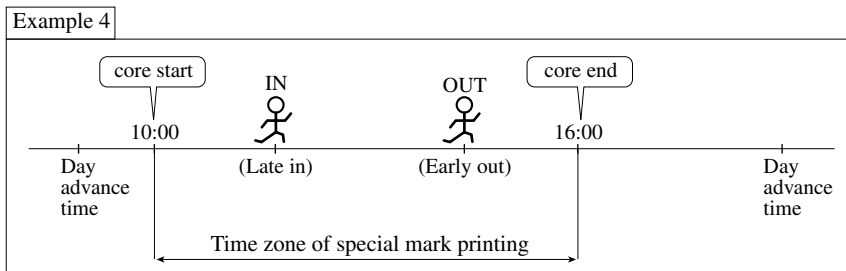

- 1 Push the **FUNCTION** button for 3 seconds.
- 2 Push the **FUNCTION** button and position the "▲" under the "COMMON SCHEDULE" mark.

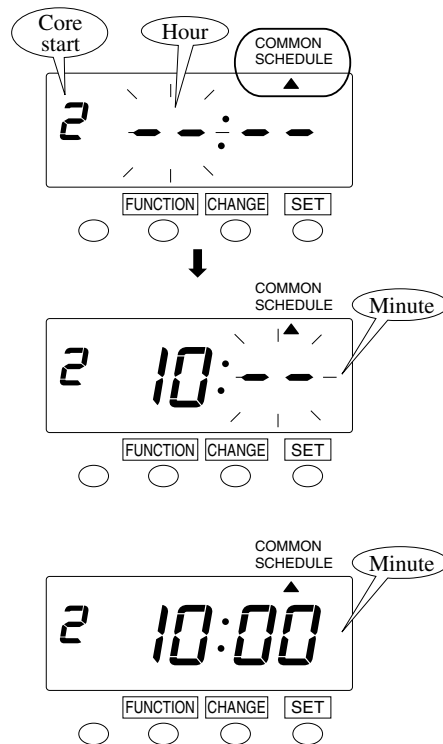

### Set the "core start" time.

- 3 Push the **CHANGE** button to set the left-side number at "2" and then push the **SET** button. At that moment, the flashing changes to "Hour". In the case of the example, push the **CHANGE** button to set at "10" and then push the **SET** button. At that moment, the flashing changes from "Hour" to "Minute".
- 4 In this case, push the **CHANGE** button to set at "00" and then push the **SET** button.

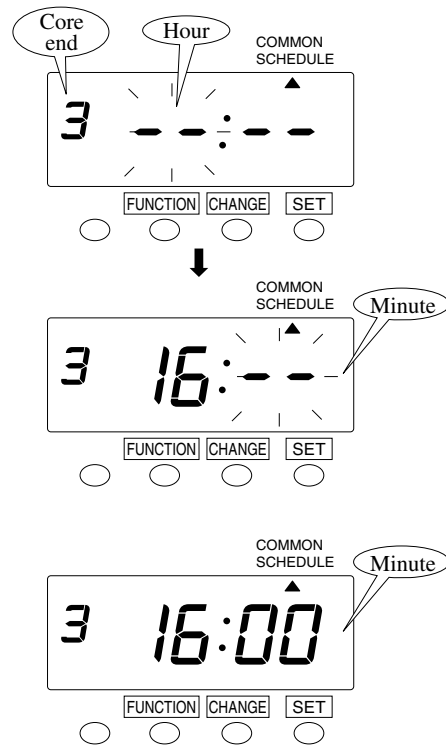

### Set the "core end" time.

**5** Push the **CHANGE** button twice to set the left-side number at "3" and then push the **SET** button. At that moment, the flashing changes to "Hour".

In the case of the example, push the **CHANGE** button to set at "16" and then push the **SET** button.

At that moment, the flashing changes from "Hour" to "Minute".

**6** In this case, push the **CHANGE** button to set at "00" and then push the **SET** button.

**7** Push the **SET** button once again.

## Setting the Rounding Punch

See "5 . WHAT YOU CAN DO WITH THE QR-375" before setting rounding punch.

Types of rounding	
1	hours (Hourly rounding)
2	punch (Punch time rounding)

Rounding unit								
1min.	3min.	5min.	6min.	10min.	12min.	15min.	20min.	30min.

Example: Type of rounding is the "Punch". Rounding unit is "15 min".

- 1 Push the **FUNCTION** button for 3 seconds.
- 2 Push the **FUNCTION** button and position the "▲" next to the "ROUNDING PUNCH" mark.

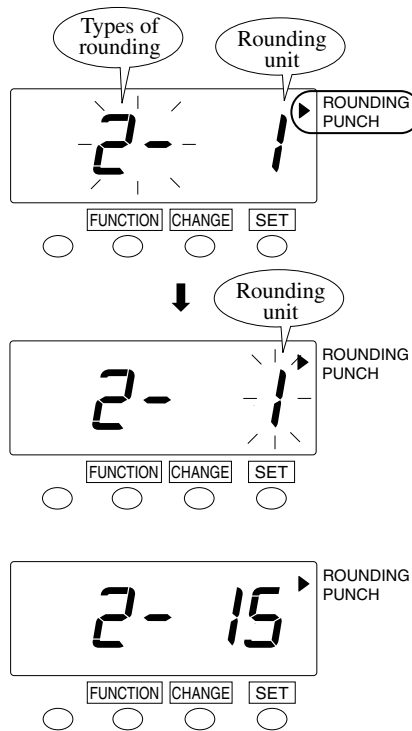

### Set the "Types of rounding".

- 3 In the case of the example, push the **CHANGE** button to set at "2" and push the **SET** button. At that moment, the flashing changes from "Types of rounding" to "Rounding unit".

### Set the "Rounding unit".

- 4 In this case, push the **CHANGE** button to set at "15" and then push the **SET** button.
- 5 Push the **SET** button once again.

## Setting the Daylight Saving Time

### Daylight saving time function

#### ❶ D.S.T. execution time

At 2:00 a.m. on the first day of summer time, the clock automatically gains one hour to show 3:00 a.m. When 3:00 a.m. comes on the last day of the summer time period, it loses one hour and returns to 2:00 a.m.

#### ❷ Setting D.S.T.

##### Example:

Start date Sunday, March 30, 2003

End date Sunday, October 26, 2003

If set as the above, the unit remembers the start date as the last Sunday of March and the end date as the last Sunday of October. Once set, the unit automatically updates the settings every year thereafter. No further manual setting is necessary.

When there is a time change between the "IN" and "OUT" because of the "Daylight Savings" settings, an "S" will appear on the calculated result as a record mark.

In order to prevent miscalculations on the day you adjust the "Daylight Savings" time, punching "OUT" the next day is not desirable.

The "S" mark may not be printed properly when "Daylight Savings" turned on because of other changes in settings.

The setting for daylight saving time will be described using the following example.

#### Example

Today (present day)	Wednesday, January 29, 2003	
Starting date of daylight saving time	Sunday, March 30, 2003	The last Sunday of March
Ending date of daylight saving time	Sunday, October 26, 2003	The last Sunday of October

**1** Push the **FUNCTION** button for 3 seconds.

**2** Push the **FUNCTION** button and position the "▲" next to the "DAYLIGHT SAVING" mark.

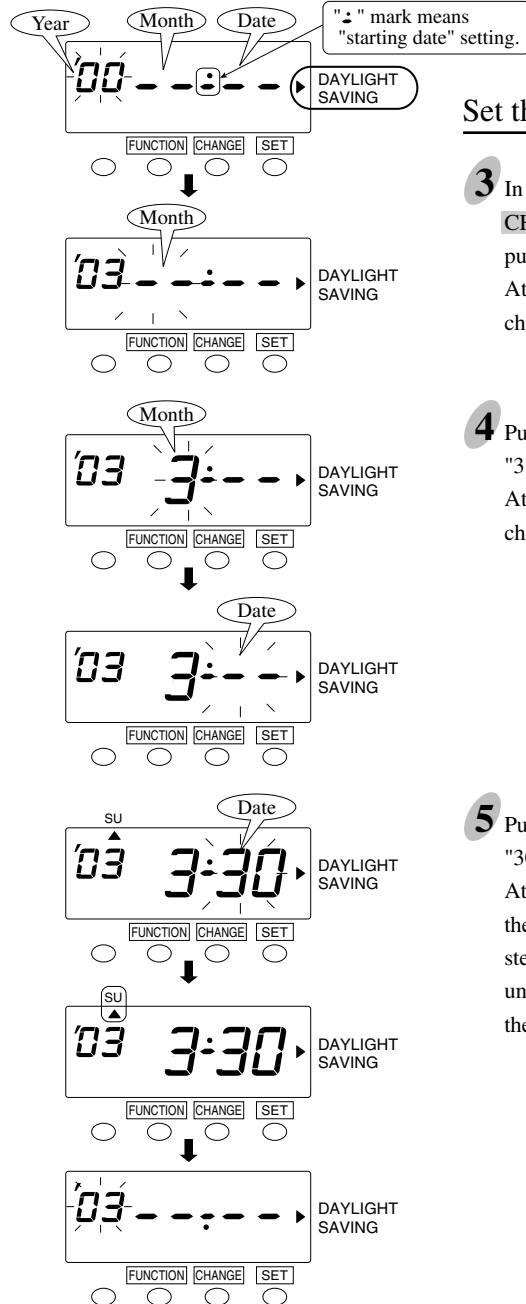

### Set the "starting date".

**3** In the case of the example, push the **CHANGE** button to set at "03" and push the **SET** button.

At that moment, the flashing changes from "Year" to "Month".

**4** Push the **CHANGE** button to set at "3" and push the **SET** button.

At that moment, the flashing changes from "Month" to "Date".

**5** Push the **CHANGE** button to set at "30" and push the **SET** button.

At that moment, "starting date" of the display changes from flashing to steady and the "▲" mark is displayed under "SU". Wait a few seconds, then start on Step 6.

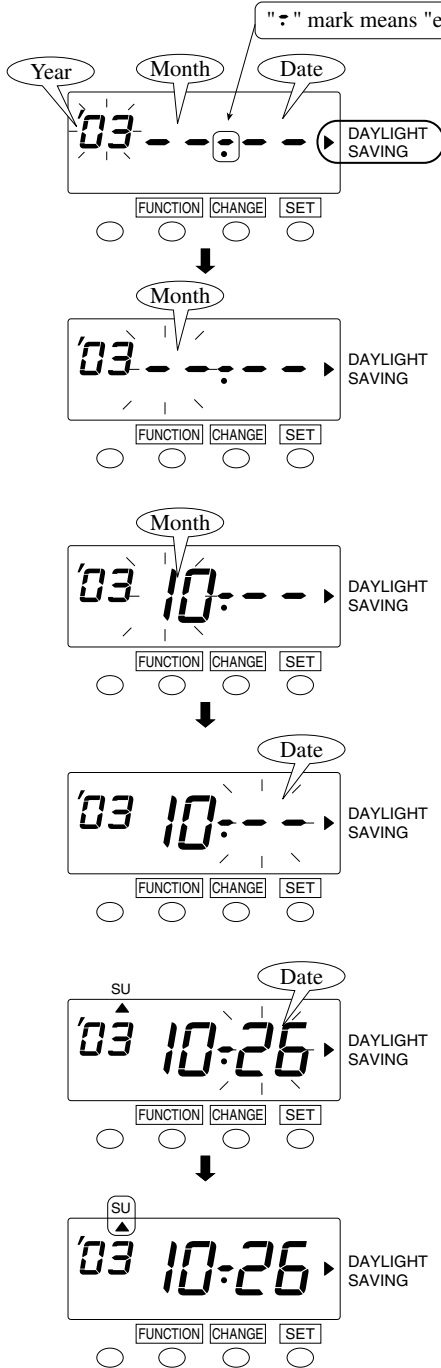

### Set the "ending date".

**6** Next, push the **SET** button. At that moment, the flashing changes "Year" to "Month".

**7** Push the **CHANGE** button to set at "10" and push the **SET** button. At that moment, the flashing changes from "Month" to "Date".

**8** Push the **CHANGE** button to set at "26" and push the **SET** button. At that moment, "ending date" of the display changes from flashing to steady and the "▲" mark is displayed under "SU".

**9** Push the **SET** button once again.



## Deleting the daylight saving time settings

To delete and cancel the daylight saving time settings, change the display of "Month" of the starting setting to "--".

### Example

To change March 30, 2003 of "starting date" and delete daylight saving time settings.

- 1 Push the **FUNCTION** button for 3 seconds.
- 2 Push the **FUNCTION** button and position the "▲" next to the "DAYLIGHT SAVING" mark.

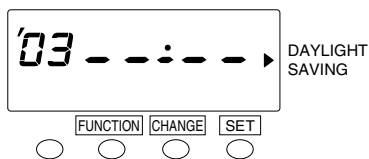
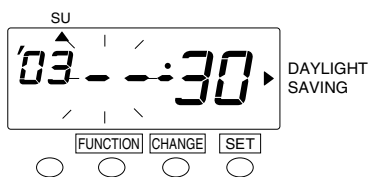
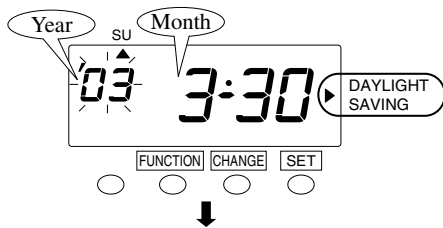

- 3 Push the **SET** button and the flashing changes from "Year" to "Month".  
Next, push the **CHANGE** button to set at "--".

- 4 Push the **SET** button twice. This cancels the daylight saving time settings.

- 5 Push the **SET** button once again.

## Setting the Print Language

This setting is available if weekly or bi-weekly closing has been selected in the previous pay period.

The print language can be selected from the following six types.

Order Options	Print <b>Example:</b> Thursday 3:30 p.m.
1. ENGLISH	TH 15 : 30
2. SPANISH	JU 15 : 30
3. GERMAN	DO 15 : 30
4. FRENCH	JE 15 : 30
5. ITALIAN	GI 15 : 30
6. PORTUGUESE	QI 15 : 30

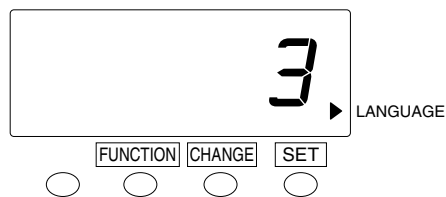
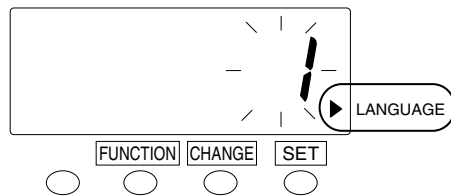

- 1** Push the **FUNCTION** button for 3 seconds.
- 2** Push the **FUNCTION** button to position the "▲" next to the "LANGUAGE" mark.  
Push the **CHANGE** button to set the number at the desired print language. For example, set 3 if GERMAN is desired.
- 3** Push the **SET** button to finish setting. At that moment, the display will change from flashing to steady, and the setting is now completed.
- 4** Push the **SET** button once again.

## Resetting

To return all settings to their factory defaults.

Please note that all settings will be deleted and will revert to the factory defaults when the reset switch is pushed. To make new settings, please refer to "6. SETTING".

If you want to reset all cards, refer to "All cards resetting" in "4. DAILY OPERATIONS".

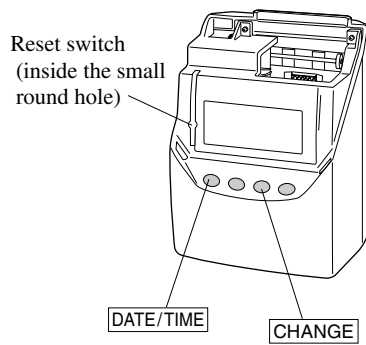

- 1 Push the reset switch with a pointed implement while pushing the **DATE/TIME** and **CHANGE** button.

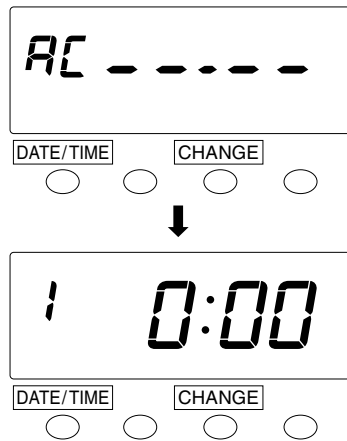

- 2 At that moment, the display change to AC "-----".  
And after a few seconds, the display changes to date & time "1 0:00".

# 7. PRINT EXAMPLE

## Settings

- For example, the first print in is made on Tuesday, March 18, 2003
- Pay period — Monthly / Closing date — 15 th
- Day advance time — 5:00 a.m.
- Rounding — Hourly / Rounding unit — 15 min.
- Schedule

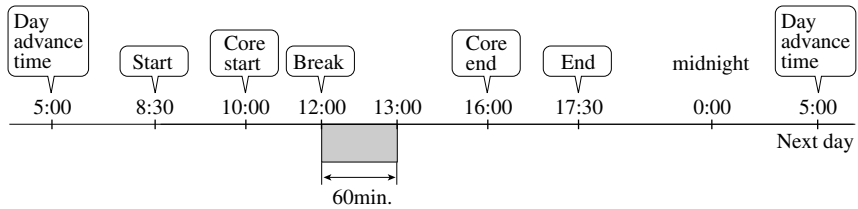

## Print example

Month	Date	IN	OUT	HOURS	TOTAL
	03 18	9:03	18 16:40	6:30	6:30
	19	9:03	19 15:10 !	5:00	11:30
	19	22:03	19 23:35	0:00	11:30 *
	20	8:07	20 18:05	8:00	19:30
	21	13:47 !	21 22:10	3:30	23:00
	24	9:03	24 16:43	6:30	29:30
	25	9:05	25 17:03	6:45	36:15
	29	8:12	29 12:20	3:30	39:45
	29	16:10	30 3:04	1:15	41:00
04	1	9:14	1 16:48	6:30	47:30
Month	2	8:53	2 17:20	7:15	54:45

Special mark printing "!" (In this case, "Early out")

Special mark printing "!" (In this case, "Late in")

Caution mark "\*" mark printing (In this case, calculation result is "0:00".)



### Settings

- For example, the first print in is made on Tuesday, March 18, 2003
- Time — 12 hour format
- Pay period — Weekly
- Day advance time — 0:00 a.m.
- Rounding — Punch time / Rounding unit — 5 min.
- Language — English
- Schedule



### Print example

Month	Day of the week	IN	OUT	Time (12 hour format)	HOURS	TOTAL
	03 Tu	9:03A	Tu 4:40P		7:35	7:35
	We	9:03A	We 3:10P		6:05	13:40
	We	10:03P	We 11:35P		0:00	13:40 *
	Th	8:07A	Th 6:05P		9:00	22:40
	Fr	1:47P	Fr 10:10P		3:40	26:20

Caution mark "\*" mark printing  
(In this case, calculation result is "0:00".)

## 8. INSTALLING THE BATTERY (OPTIONAL)

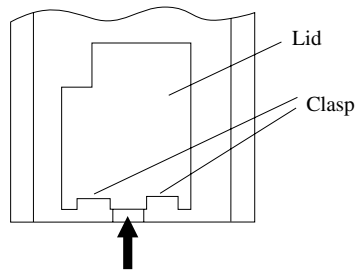

- 1 Remove the lid of the battery compartment on the back of the unit by pushing up the center of the lid, and then release it from the two clasps.

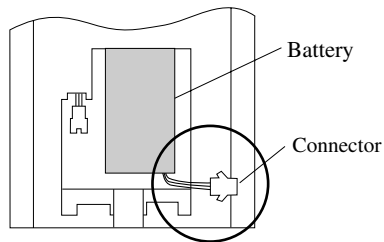

- 2 Position the battery as shown in the figure on the left .  
\* The connector cord should be on the right side, as shown in the figure.

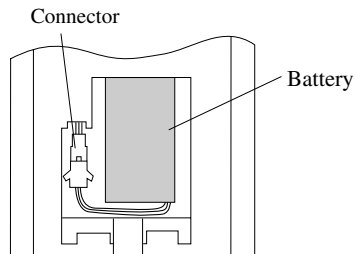

- 3 Connect the connector. Tuck away the connector cord into the open space in the compartment.

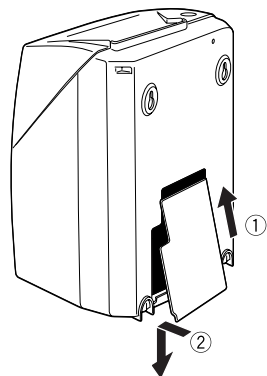

- 4 Insert the lid into the slot as shown on the left. Keep pressing it down until it hooks to the clasp.  
\* Make sure the cord is not caught when closing the lid.

# 9. TROUBLESHOOTING

## Error No. appears

No.	Error contents	Action
E-00	CPU error	Contact the store from whom you bought the unit.
E-01	The remaining life of lithium battery for memory back-up is short.	
E-03	The front and back of the time card inserted is wrong.	Correctly insert the time card.
E-05	The card is not pulled in properly.	Make sure that another time card is not jamming in the time recorder. Try inserting the time card again.
E-15	Card sensor error	Make sure that another time card is not jamming in the time recorder and the ribbon cassette is correctly inserted in place.
E-30	The printer motor or the sensor is not normal.	After making sure of the above, close the cover.
E-37	The card forwarding motor or the sensor does not operate properly.	If the error number is still displayed, contact the store from whom you bought the unit.
E-38	The print head motor or the sensor for the printer head can not operate properly.	
E-41	The start date and the end date of the daylight saving time are the same date.	Correctly set the daylight saving time.
E-49	Input the wrong figures.	Check the setting contents and input the correct figures.
E-50	Can't use the time card.	Check the bar code area whether it is smudged or damaged.
E-51	Print error	Check whether the time was turned back or not. Also check whether the card was inserted within 1 minute after the last punch.
E-53	Over 50 time cards are used.	Check the number of the cards, which are used in current pay period and reset as needed.
END	When the card that you are using becomes full before reaching the "Pay Period" day.	Use the "Card number transfer" mode to transfer the card and have a new card take over for the old one.

## 10. SPECIFICATIONS

Clock accuracy	Monthly accuracy $\pm$ 15s (at ordinary temperature)
Calendar	Year up to 2099. Automatically adjusted to leap years, 31-day months and months with thirty or fewer days, and the days of the week.
Printing system	Dot matrix
Power failure compensation	Five years of cumulative power failure hours after the date of shipment
Print at power failure	Optional battery, 100-time printing or 24 hours
Memory capacity	50 employee capacity
Operating environment	Temperature: $-5^{\circ}$ to $+45^{\circ}$ C : $+23^{\circ}$ to $+113^{\circ}$ F Humidity: 20 to 80%RH, no condensation The unit operates normally at temperatures of $5^{\circ}$ C or below, but the print density, reaction of the liquid crystal display, and the number of prints at power failure are inferior to those at normal temperature operation.
Dimensions	6.3" (w) x 8.07" (h) x 5.04" (d) 160 (w) x 205 (h) x 128 (d) mm
Weight	Approx. 3.3lbs. (1.5kg)
Rating	120VAC 50/60Hz 0.24A 220-240VAC 50/60Hz 0.17A



# 10. Technische Daten QR-375 und Zubehör

---

## Technische Daten

### Drucksystem:

Vollautom, Stempelkartenanzug und -ausgabe, Zeitregistrierung schwarz Nadeldrucker, für doppelseitige Stempelkarte mit 6 Spalten und optischer Seitenerkennung. Zeitregistrierung wahlweise in Stunden und Minuten oder in Stunden und 1/100 Stunden mit Datum 1-31.

### Display und Bedienfeld:

Multifunktionale LCD-Anzeige für Uhrzeit, Datum, Wochentag, Sommerzeit und Druckspalte, sowie als Bedienfeld für die Programmierung.

### Uhrenfunktion und Kalender:

Echtzeituhr auf Quartz-Basis mit Dauerkalender bis zum Jahre 2098. Ganggenauigkeit  $\pm 15$  Sek. / Monat, Datensicherung des Programms bei Stromausfall ca. 5 Jahre.

**Sommer-/ Winterzeitschaltung:** Vollautomatisch am Ereignisstag.

**Datumsortschaltung:** Vollautomatisch, Zeitpunkt programmierbar,

**Notstromversorgung(option):** Gangreserve für ca. 24 Std. oder 100 Registrierungen.

**Farbversorgung:** Farbbandkassette schwarz/rot.

### Umgebungsbedingungen:

Temperatur  $-5^{\circ}\text{C}$  bis  $+45^{\circ}\text{C}$ . Rel. Luftfeuchtigkeit 20% bis 80% (ohne Kondensation).

### Netzspannung/Anschluß:

220-240 V  $\pm 10\%$ , 50-60 Hz, Leistungsaufnahme ca. 0,17A. Netzkabel 1,7 m lang.

### Gehäuse/ Farbe:

Hochschlagfestes Kunststoffgehäuse mit Schloß. Seldel-/ Platingrau strukturiert.

**Abmessungen:** H160x B205 x T128mm

**Gewicht:** 1,5Kg (Netto)

Technische Änderungen vorbehalten





SEIKO PRECISION INC.

ALL RIGHTS RESERVED  
©2002 & 2006 SEIKO PRECISION INC.  
Q0131-6120-3